

Building Robotics & Electronics With Chris @ PyroElectro.com

Learn The Inns And Outs So You Can Build Your
Own Custom Robots

Chris @ PyroElectro.com

9/1/2010

Table of Contents

<u>Chapter 1 – Introduction</u>	3
<u>What? No “One Time Offer”?</u>	3
<u>Tomorrow Never Happens</u>	4
<u>Chapter 2 – My Recommended Suppliers</u>	5
<u>Online Distributors vs. Local Stores</u>	6
<u>Chapter 3 – Beginning Tips For A Robotics Hobbyist</u>	7
<u>5 Hobbyist Mistakes To Avoid</u>	8
<u>Eight Habits of a Successful Engineer</u>	9
<u>What To Do When Things Go Wrong</u>	10
<u>Theory vs. Experimentation</u>	11
<u>Five Thing To Do When You Are Not Sure What Is Next</u>	12
<u>Chapter 4 – Basic Robotics Knowledge You Need</u>	14
<u>The Fundamentals of Robotics in 3 Pages</u>	14
<u>A Short Theoretical Example</u>	16
<u>Program Only If You Want To</u>	17
<u>The Tools You Will Need</u>	18
<u>Chapter 5 – Make Intelligent Circuits</u>	21
<u>Intelligent Design: Digital vs. Analog</u>	21
<u>The Parallax STAMP</u>	21
<u>The Microchip PIC</u>	22
<u>Analog Madness</u>	22
<u>Chapter 6 – A Project Anyone Can Make (Flashy Things)</u>	23
<u>What You Need To Build It</u>	23
<u>What You Are Building</u>	23
<u>How You Build The Circuit</u>	25
<u>It Works! What Now?</u>	29
<u>Chapter 7 – Case Study: Build Your First Robot</u>	30
<u>What You Are Building</u>	30
<u>What You Need To Build The Robot</u>	33
<u>How The Robot Works</u>	35
<u>How You Build The Robot</u>	38
<u>The Robot Works! What Now?</u>	42
<u>Chapter 8 – The PyroElectro’s Story</u>	44
<u>University Life</u>	44
<u>Professional Life</u>	45
<u>Appendix – Mechanical/Electrical Parts</u>	46

Chapter 1 – Introduction



What? No “One Time Offer”?

If this was your typical “buy this robot kit here and build it” robotics E-Book, this would be the part where you would get a sales pitch about the “Once in a Lifetime Offer”. After spending \$100, the author would try to sell you some parts and then tell you to follow the instructions in the kit. The next chapter would tell you to spend \$1000 on an even cooler robot. Don’t get me wrong, [\\$1000+ robots](#) are awesome, however you would not have learned how to make anything, just how to follow instructions and spend money.

You will not find any sales pitches or one time offers in this E-Book because this book is not meant to make me money, it is meant to teach you how to design and build your own robotics. I am an electronics and robotics enthusiast and I believe that this E-Book should be free. In fact, I encourage you to make copies and share it with anyone you want. All I ask is that you do not change the content.

The main reason I chose to write this E-book is because I get e-mails every day asking about electronics, robotics and circuit design. I decided that I wanted to create a resource for enthusiasts like me that quickly answered many of their questions. While I could have chosen to sell this book and make money from it, my real plan is slightly more evil. I want the world to be taken over by robots.

[Chris @ PyroElectro.com](http://Chris@PyroElectro.com)

Tomorrow Never Happens

Beating the Learning Curve

Have you ever heard someone say: “I’ll do it tomorrow”? Well surprisingly enough, “tomorrow” never happens. Talk to anyone who has had a successful career and they will tell you how important budgeting your time is. This is an important lesson to learn, especially as you undertake learning something new and difficult.

Learning about robotics and getting a good understanding of the electronics that control them will take time. So keep realistic expectations and do not expect to be building Wall-E by tomorrow morning. When you do run into problems and need answers, take a break, a deep breath, look at a few of the recent projects at [PyroElectro dot Com](http://PyroElectro.com) to help refresh your brain and then continue on.

When it comes to building robots, every engineer has dreams and goals. Take a moment and think about how many goals in life you have achieved and how long it took to reach them. Remember your dreams as you get started in this field and it will help you keep perspective of the progress you make and the goals you still wish to reach.

Putting a Time Limit on Success

It is not enough to only dream of becoming a success. Many people dream of being a success but stop short of actually trying. Don’t believe it? Well this is exactly what people do every day with dreams of success; they have the dream but not the desire. They say to themselves, “I will do it, eventually.”

We have only a short amount of time on this earth, so why waste it? If you want to do anything great, you need to put a time limit on how long it should take and you must follow through from beginning to end. You have to recognize that you will fail, but remember to recognize failures and keep up hope that a success is one step away. Remember, all successful people have had many failures in their lives. Even Thomas Edison failed more than 1,000 times while trying to invent the incandescent light bulb.

Building robots is something many people want to do. Every little kid dreams of building a machine at one time or another. However, very few have gotten serious about it. The reason for that is simple, the successful people actually started reading, testing, experimenting, building and not just saying “Awesome, I want to do that too!” like the rest of the crowd.

Chapter 2 – My Recommended Suppliers

My favorite robotic and electronic parts suppliers are listed out below. I use them all for the parts in my tutorials and projects. I picked them out of a very long list of over 50 parts suppliers to show you where to go to get the best parts. The customer service, pricing and selections these companies offer are all top notch and you will not be disappointed.

Jameco



Jameco is an electronics component distributor and it is the first place I look when I need parts. They carry every type of passive and active electronic component that you can think of. Jameco is where people go when they need rock bottom prices on parts and great quality. They offer single and bulk purchases, which is ideal for the individual hobbyist and for larger companies. Be sure to check out their weekly specials.

[See Jameco Here](#)

Trossen Robotics



Trossen Robotics is a smaller online shopping site that distributes specialty parts. They have a great selection of specialized robot parts, sensors and pre-built electronics that can save you time when you are working on a project. If you are not in the mood to start a design from scratch, this smaller shop is a great resource for you.

[See Trossen Robotics Here](#)

Parts Express



If a large distributor like Jameco does not have the part I need, the odds are good that Parts Express will have it. This is my second go-to shop when I need to get some simple electronics, PC Board, solder or protoboard. Parts Express has weekly specials and electronics kits that are great for hobbyists just starting out.

[See Parts Express Here](#)

Amazon



Amazon has become a true powerhouse for companies trying to sell a large range of products. A large variety of electronic components and tools can be found on Amazon and since Amazon has a very competitive nature, their prices are typically rock bottom. With brand name soldering tools by Weller to electronics kits by Tamiya, Amazon has a large quantity of great robotic parts and tools.

[See Amazon's Robotics Section Here](#)

Sparkfun



Similar to Trossen Robotics, Sparkfun has a lot of specialty electronic and robotic parts that are great for hobbyists. They offer many prebuilt electronic devices and robotic kits at low prices. There is also an active forum on their website for support with any items that you purchase.

[See Sparkfun Here](#)

Online Distributors vs. Local Stores

One thing that people often ask me is whether it is worth it to go to a local electronics store instead of ordering off the internet. If it is more convenient for you, then by all means, go to the hobby store or the electronic store near you. I do not discourage it, because you will probably meet like minded individuals who are excited about anything robotics or R/C. However, a word of caution: hobby stores will often charge upwards of 500% markup on simple items like resistors and capacitors. Items that should cost 5 cents will be 1 dollar or more!

Aside from meeting other people who are actively building their own robots, getting your supplies from local hobby stores is usually just not economical, especially if you are on a strict budget. The larger online distributors often have weekly specials and package deals that simply cannot be beat by the smaller chain stores.

So my advice is twofold when it comes to this debate: Know where the stores are nearby your home so you can pickup parts if you need them right now. However, try your best to plan ahead and buy parts in bulk from online component distributors. I do not discourage either method because I actively encourage the building of robots!

Chapter 3 – Beginning Tips For A Robotics Hobbyist

Learn & Build For Your Passion

If you are not passionate about what you're learning, you will not keep with it. The same can be said about building something. Failures will bring you down, but you must know whether or not you will be able to pick yourself back up and work double hard to find the right solution.

Find Additional Reading Material

While it is possible to use the internet to find all the answers you need for theoretical and experimental questions that you will have, I recommend that every robotics hobbyist have a few of the basic textbook resources to turn back to.

There are a select few websites that offer great tutorials and step-by-step theory lessons on the basics of circuits, robotic design and programming. These websites are terrific for hobbyists who are working on a budget. However, while they often cover the basics very well, they rarely cover advanced topics with full clarity and that is why I suggest getting either an E-book or real textbook as a supplement to your internet resources.

It is better to begin collecting a few hardback textbooks in the beginning, rather than starting later down the road. You will be grateful to be able to physically hold a printed copy of that one perfect design example.

Getting To Know Other Robotics Enthusiasts

There are so many different resources and forums where fellow electronics and robotics enthusiasts come together to discuss or show off new designs and even mock professional designs. You really need to poke your head in and at least introduce yourself, ask a question or two and definitely keep your eyes peeled for good conversations. Everyday engineers and hobbyists are thinking up new ideas that you might be able to use for a design.

Check Out These Awesome Forums:

<http://www.edaboard.com/>

<http://www.electronics-lab.com/forum/>

<http://forums.trossenrobotics.com/>

5 Hobbyist Mistakes To Avoid

Throwing In The Towel

It happens like clockwork. Someone with high hopes buys a few books, some electronics parts and a really expensive robotics kit and is extremely excited about getting started. They start learning how things work and then their mind wanders onto something else. Slowly, dust accumulates on all the parts and the books become doorstops. By the end, everything is on a shelf somewhere for a rainy day. If you are serious about understanding electronics and building your own robotics, you need to make a commitment to spend time learning and building, whether it is on weekends or half an hour a night.

Rushing a Project

Everyone is guilty of this at one time or another. You are extremely excited about a project you have been working on, so you quickly draw up a design that probably will work, and then get building with your fingers crossed. The project is built and it does not work. Now you are back exactly where you started except you burned a few hours. Before you start building test, double check and remember the golden rule of “measure twice, cut once.”

Not Taking Advice

If you become active on a forum or with a local robotics group, you are going to receive negative comments and opinions about your work. While many of them will not be very constructive, some will be. You will have to learn not to be offended but to instead take the comments and apply them to your project and see if your design could actually be improved.

Not Giving Advice

On the other end of the spectrum, once you have gained knowledge, there will be many people who are in the position that you used to be in as an amateur. If they have a question, give them a good answer. Not only will it help your understanding, as teaching others often does, but it might get you thinking of ideas for how to better approach the problem at hand.

Not Reading PyroElectro dot Com

This is probably the gravest mistake anyone could make. I think we can all agree on that!

Eight Habits of a Successful Engineer

Know What You Are Building

Knowing exactly what you want to build is the first and most important habit for engineers. To be effective and successful you need to be able to have your idea in mind and translated onto paper. This skill will make it easier to explain to others what the plan is, as well as to remind yourself as you progress what the goal is.

Focus Only on the Most Important Things

It is so easy to lose focus while working on a project. There are distractions, new ideas and a hundred other things that will come up. The challenge is to stay focused on those activities that will deliver the most progress towards finishing your project. “The main thing is to keep the main thing the main thing.”

Keep Track of your Results

If you do not know where you started, how will you know how far you have come? I have seen people make this mistake many times during my career. Successful engineers always take time to understand the starting point, the starting point being the design of the project. Then, as the project progresses, they are so excited to get a finished product, no documentation is recorded on paper because it is not as fun as building. Always be sure to take some photos, and write down what you have done for the hour/day/week on the project. This will be instrumental for when you start working on other future projects that are similar.

Use Tools to be More Effective

I admit it! As an engineer and hobbyist, I love to dig in to the details and use my engineering knowledge to sniff out the root cause of a problem. This is part intuition, part experience and part of the engineering mindset. If you love to solve problems, it can be easy to overlook that there may be simpler ways to get the job done.

Network and Communicate Results

This is probably the most important of these 8 habits. If you do great things, and nobody knows what was done, no one will care and no one will benefit. Networking is a critical part of life. I

am not talking about computer networks, but with people. Make sure you have credibility with a wide array of people. Think outside normal workday routine; comment on blogs, get more active on linkedin or start up a conversation in a forum.

Keep Learning

Never stop learning. One of my great mentors had been working at a NASA center for over 40 years. He seemed to know the inner workings of every machine, instrument, valve, transformer and other device under the sun. In working with him, I learned why. He had a natural curiosity and he was never afraid to ask questions. In a group of people, he would often say, "I wonder how that works..." and sure enough, someone would explain it.

Share Your Knowledge

Even long after paying for my own college education, my parents still have only a vague understanding of what it is that I do as an engineer. Even within my company, there is often a vague mystery associated with my duties. With that in mind, I urge you to share your knowledge with others. It can help to make you and your coworkers more effective. For your own success, if people understand what you do, they will have a better appreciation of the value you bring to the company.

Reading PyroElectro dot Com

This is actually 100% true. As an engineer and hobbyists I am constantly looking at other people's designs and comparing them to my own. Seeing what other people create will give you ideas of your own and help you create more unique solutions.

What To Do When Things Go Wrong

When People Are not Impressed

When I think back to my beginning days with robotics, making it so that an LED could flash at a certain frequency was enough to get me excited. After hours of connecting a rom, ram and cpu together and writing many, many lines of assembly code it worked! So what was the first thing I wanted to do? Show it off. Needless to say my liberal arts roommates were never as excited as I was. They did not understand the hard work that it took to build. Take this lesson and understand that people are not always going to give you the congratulations you deserve.

However, this will give you a chance to learn how to explain sophisticated electronics to normal people, in a way so that even they become impressed.

The Project Is Officially A Dud

You are going to run into failures. Recognizing that fact and being able to realizing when a project has no chance to be completed is important. Not that I want to encourage giving up, but choosing different paths to finish a project is something you should always consider and yes, sometimes that means starting over from scratch.

Negative Comments Are a Good Thing

While it might sound strange to hear, you should look forward to hearing negative comments because it means people recognize your skill and are not sugar-coating things for you anymore. This does not mean you should try to make people pissed off on purpose, that would be dumb. What it does mean is you cannot please everyone all the time and there is no reason to try.

On a separate issue, negative comments can be interesting, especially if they are constructive. People in forums feel that they are behind a veil of anonymity and usually unleash their opinions with no holds barred. For example, at a place like Digg.com negative comments seem to run rampant but they encourage discussions to continue.

How to Handle a Negative Comment

Being professional really is the best way to handle a negative comment. Thanking them for their input and commenting on their issue. If you return fire at them, you will not accomplish anything positive and for the most part will just be wasting your time. Remember negative comments come after the sugar-coating wears off from the people who enjoy looking at what you are designing. This means that you are getting good and people are starting to actually care and take real interest in what you are doing.

Theory vs. Experimentation

Think With Your Brain, Build With Your Hands

Some people's brains are wired so that they need to draw something on paper and work out the math to get the "must have" understanding of what is going on. They love to think about

how something would work in the theoretical, write it down and then move to test it out on an experiment.

On the flip side, other people's brains are wired so that they need to throw something together as an experiment and get a working product, then move to the paper to describe how and why the system works. The true understanding comes later on in this process.

Both types of people are effective designers, but their process of creating a solution is unique to themselves. Finding out what kind of a robotics tinkerer you are is important for understanding how you will approach creating a design. If you understand what your brain wants first, to play with parts or to write something on paper, then you will be able to more easily see a project through from beginning to finish.

No one method for creating a solution exists and it is very important for any hobbyist to understand that. A certain amount of experimentation and theoretical work will need to be done before any project can be successfully completed; exactly how much depends on the individual.

Five Things To Do When You Are Not Sure What is Next

See What Everyone Else Is Doing

There are so many resources in libraries, bookstores and on the internet. Looking at what other people are talking about in forums and projects that people are putting online for the world to see will give you many new ideas for what to do next. In the end it really just depends on what your goals are for your projects and what area interests you most.

Take A Look At Your Old Projects

Going back to the storage area and pulling some of your old projects out of the box can be a great motivator. It shows you that you can complete projects and how far you have come since you started building robots. Many times, looking at your old projects will remind you of how one of them could have been built better and stifle your creativity to build version 2.0.

Clean Up Your Work Area

As you are learning and experimenting with electronic and robotic parts your work area is going to get cluttered with excess parts. Cleaning the area up while you are down on ideas will do two

things: (1) get you very good at reading resistor color codes and (2) give you ideas for a new project using parts that are just lying around doing nothing.

Look At Tools You Wish You Had

Nothing stifles my creativity more than walking through a gigantic electronics component supply store. Looking at the parts that I wish I could have and the tools I could be using gets my brain thinking about what I could do with those parts or how I could actually build that tool on my own with the right parts. Looking online at parts is great, but nothing compares to seeing rows and rows of various sensors, resistors, capacitors the size of my hand and motors the size of my face.

Read More PyroElectro dot Com

When I am running low on Ideas, I usually sift through some websites that have daily project posts. [PyroElectro dot Com](#) is mine obviously, but I recommend also taking a look at the projects on [HackADay](#) and [HackedGadgets](#). These websites and my own have hundreds of cool projects posted, many are from normal robotics and electronics enthusiasts like you or me who want to show the world what they have made.

Chapter 4 – Basic Electronics Knowledge You Need

Listen, I will be realistic with you and say that it is impossible to jam-pack all the knowledge and experience you need to have and know about the basics of robotics into a few chapters of a book. In fact, no book could hold all that information. The knowledge you need will differ from person to person and books unfortunately do not cater to that need.

What will I do for you? I will get you headed in the right direction, give your inquisitive mind a jumpstart and show you what areas you need to study more. You already know a lot more about robotics and electronics than you might think. Just watching simple things like how water flows teaches you how the theory of circuits works as you will soon see.

The Fundamentals of Robotics in 3 Pages

Electrical Fundamentals

Understanding how the flow of electricity works will save you hours of trying to understand theory in a textbook. Look at the picture to the right. On the left side there is a bucket filled with water sitting on a stool and a pipe coming out of the bucket filling water into another bucket on the ground.

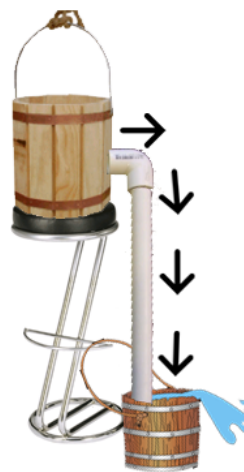

Flow of Water

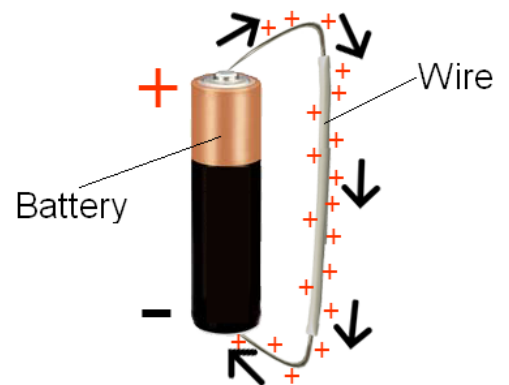

Flow of Electricity

Why do we know that water flows this way? Through experience and intuition, through just living day to day. Luckily, electricity flows in a similar way.

Take a look at the picture on the right side. We have a battery and a wire connecting the top (+ sign) and the bottom (- sign). Electricity will now flow through the wire, just like water did through the pipe. It starts from the top (+ sign) and ends up at the bottom (- sign) also called the ground. The flow of electricity in any electronics that you have ever used operates in this way, no exceptions. It flows from + (positive) to - (negative)

The basic building blocks of circuits

The Resistor

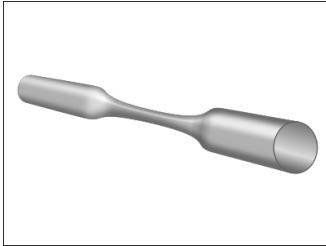

A resistor can be thought of as a piece of pipe with a narrower region. Water cannot flow as fast through this kind of pipe.

The Capacitor

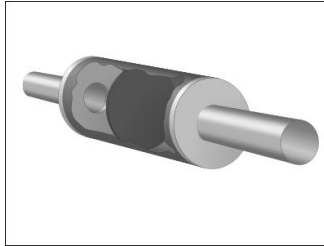

A capacitor is similar to a tank which can be filled up and emptied. Water cannot flow through it, but it can store water.

The Transistor

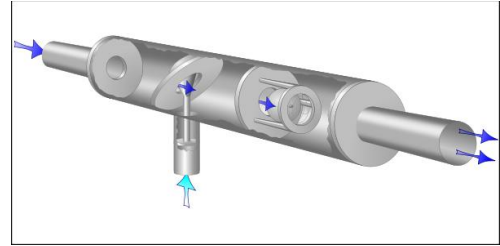

A transistor is more complex. In a circuit it is used for switching (turning things on and off). The amount of water that can flow through the pipe depends on how much is flowing in from below.

Mechanical Fundamentals

The mechanical equivalent of a muscle is a motor. Many different types of motors exist but they all do the same thing: turn electrical energy into physical (mechanical) energy. This is how robots are able to turn wheels, move limbs or blink mechanical eye lids.

Learning the art of motion control should be the primary goal of any robotics hobbyists because that is exactly what robotics means. You are trying to convert electrical energy into physical energy in order to create something that can move, makes noises or even walk, but in an intelligent way!

Gravity, Friend or Foe: When you begin to design the mechanical parts of your robotics systems you will run into issues that relate to gearing, torque and understanding how much raw force is necessary to move something from point a to b.

Torque measurements will come with the motors you buy and after a certain time of experimenting with motors you will get a feel for how the numbers (Newton meters and Ounce inches) relate to a motor's power.

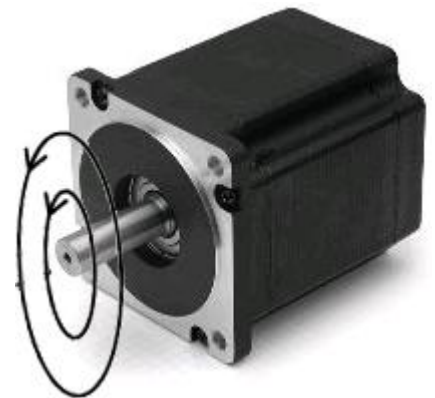

Gearing is another design advantage that can be used when you need more performance out of a motor. Similar to how your bicycle works in the different gears, motors can be geared up to spin faster or slower with less force or more force.

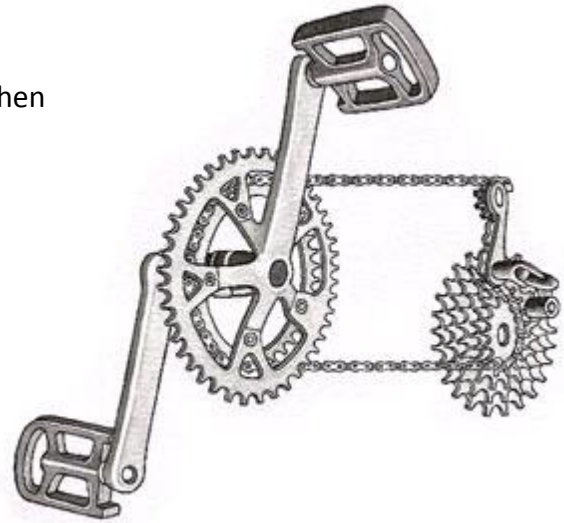

Gravity is your main adversary in this fight for intelligent motion control. At times you will have to search around the internet or dust off an old physics book to calculate exactly what a motor needs electrically to turn a wheel or grip a pencil.

Recommended Reading Material

- (a) [Electric Circuits by James Nilsson and Susan Riedel](#)
- (b) [Microelectronics Circuit Analysis and Design by Donald Neamen](#)
- (d) [Engineering Fundamentals by Saeed Moaveni](#)
- (e) [Mechatronics by William Bolton](#)

A Short Theoretical Example

Electrical Theory

In electric circuits we want to find the voltage level at certain points. Given some input voltage seen below as V1. V1 could represent 2 AA batteries or a 9v battery, it does not really matter because the formulas will remain the same no matter what the above values are.

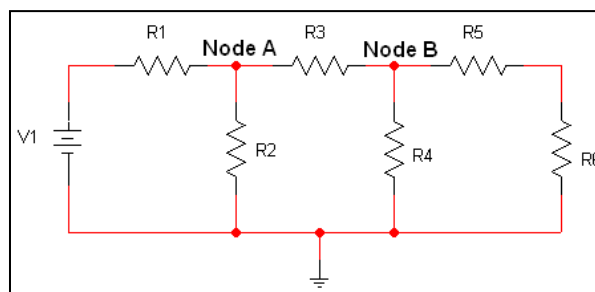

A Standard Electric Circuit

For this exercise we are interested in knowing how to calculate the voltage at the point between R1, R2 and R3, node A and the point between R3, R4 and R5, node B. These two

'nodes' or points will have a different voltage depending upon the resistor values.

The fundamental equation of electronics is called Ohm's law. Any electrical engineer will know this law and will live by it as a daily necessity. The law is as follows:

$$\mathbf{Voltage = Current \times Resistance}$$

A second law of electronics states that the voltage provided to a circuit (for example a 9 volt battery) is equal to the voltage used in the circuit. Similarly, the electric current provided to a circuit should be equal to the electric current used by the circuit.

To solve the question posed above we will use a method called 'Node Voltage Analysis'. This method sums up the voltage in the circuit using basic algebra and then we can solve for whatever value we need.

Node A

$$\frac{A-V1}{R1} + \frac{A}{R2} + \frac{A-B}{R3} = 0 \quad \rightarrow \quad A \left(\frac{1}{R1+R2+R3} \right) = B \left(\frac{1}{R3} \right) + V1 \left(\frac{1}{R1} \right)$$

Node B

$$\frac{B-A}{R3} + \frac{B}{R4} + \frac{B}{R5+R6} = 0 \quad \rightarrow \quad A \left(\frac{1}{R3} \right) = B \left(\frac{1}{R3+R4+(R5+R6)} \right) + V1(0)$$

At this point we have the two equations that represent how to find the voltage at node A and node B. If we have all of the element values in the circuit, you just need to plug them into the equations above and solve, simple as that. I will leave the formulas in variable form to show that no matter what the numbers are, the answer will not change how the formula works. This is just a quick introduction to some circuit theory; do not sweat it if you got a little lost.

Program Only If You Want To

A fear that most people have is that they will have to spend hours if not days indoors cooped up in front of their computer in order to get things to work just how they want to them to. Honestly, the people who end up doing that do it because they love it and love what they are doing, not because they have to do it.

Programming is the task of writing some preset instructions for a robot to follow. It is a creation of the modern digital age that allows us to do so many of the cool things we love to do like: use cell phones, browse the internet or even drive modern cars.

Programming robots in recent years has become simpler than you might think. Yes, I will admit that some research institutes will have many computers hooked together with millions of lines of computer code linking them together. However, the newer methods of programming are not all cryptic text based and use a flow-chart type of programming. This gives an advantage to hobbyists who are just starting out.

Alternatively, if you have no desire to program at all, there is another path that you can take: Analog Electronics. Analog design is all but a lost art form. This is due to the fact that turning to a digital equivalent was easier and sometimes cheaper. However, even with the digital revolution analog design is still a necessary skill for engineers to possess. Any commercial device that is wireless will have had several analog design engineers working on that product.

To clarify: Digital Electronics use 1's and 0's which can be stored, compared and processed in order to make intelligent decisions. Analog Electronics use physical components and the flow of electricity to make intelligent decisions which happen infinitely quicker than any digital electronics could.

The Tools You Will Need

Digital Multimeter

The first and most important tool that you will need is called the digital multimeter. It can measure the 3 basic electric elements: Current, Voltage and Resistance. For hobbyists, I recommend finding a low cost digital multimeter (DMM). They do the same job as their more expensive brothers, but lack some sophisticated tools that you won't need when starting out. The more sophisticated DMM's will be your life saver after you have had a few months time experimenting.



[Low Cost Basic DMM](#) (Start With This)

[High Quality Fluke DMM](#) (Then Consider Getting This)

Oscilloscope

After you are familiar with the DMM you will want more tools and more ways to be able to see what's going on inside of your robot's electronics. The Oscilloscope shows you a graph of voltage vs. time. That means, the X-axis is time and the Y-axis is voltage. Knowing the voltage of a circuit at any time is important in electronics because things are moving so quickly, there is just no other way to keep track of the micro-second changes!



[Low Cost USB Oscilloscope](#) (Great For Starting With)

[Analog Oscilloscope](#) (Old School)

[High Quality Tektronix Oscilloscope](#) (More Than You Will Ever Need)

Power Supply

What is a good power supply? It is a device that outputs a constant voltage. Think about inside your house. All the power outlets in your house probably use 115VAC. Now imagine if sometimes it became 90VAC or 150VAC. The light bulbs in your house would likely explode and many bad things would happen. All electronics are designed to be powered by a good and stable power supply, so use one!



[Single Output Power Supply](#) (Start With One Of These)

[Variable Triple Output Power Supply](#) (Single to Triple)

[Variable Digital Power Supply](#) (For Pro's)

Function Generator

When you want to test your robotic sensors and analog/digital electronics a function generator is a great tool to have. They can create specific electronic voltages that mimic analog or digital signals which can tell you if a motor is working, or that a sensor can collect data. Typically you will not need a function generator until you are well into the world of designing electronics for robotics.



[Simple Function Generator](#) (For Hobbyists)

[High Quality Function Generator](#) (For Pro's)

Soldering Iron

This last tool is like the paint brush is for an artist. The Soldering Iron is used to connect electronics together. After you have designed the controls for your robot, you are going to need to wire it all together and soldering is the way to keep these wired connections permanent. Solder is a metal that when warmed to 500-800°F turns into a molten liquid. This liquid likes to bond with the copper in wires and keep them bonded together forever.



[Basic Soldering Iron Pen](#) (Good For A Low Budget)

[Quality Soldering Iron Station](#) (What I Use)

[Industrial Quality Soldering Iron](#) (What I Wish I Use)

Chapter 5 – Make Intelligent Circuits

Throughout this chapter I will introduce you to a few of the favorite hobbyist solutions to creating intelligent circuits. They range from being simple devices with very few pins and a basic programming language, to large high frequency processors that take multitasking to the extreme. I will also introduce you to the other side of the electronics world that is known as analog design.

Intelligent Design: Digital vs. Analog

The current state of the art has a gigantic lean towards using digital design solutions. While initially in the past analog solutions were the only ones that existed, the digital age changed everything. Billions of dollars were invested to perfect the digital standard and improve the technology. Analog design can still be seen in radio frequency and custom electronics, but overall, it has mostly vanished.

The reason digital took over the electronics scene is because it is much easier to work with and also easier to learn. Ask anyone what the difference between 1 and 0 is and you will always get a correct answer. However, if you ask someone what the difference between a sine wave and a cosine wave is, more often than not, you will get blank stares from puzzled faces. Digital electronics deal with 1's and 0's as a way of storing, comparing and processing information. Analog electronics deal with functions of time and physical elements for storing, comparing and processing.

The Parallax STAMP

Being a Hobbyists' true favorite, the Parallax STAMP (a small microcontroller) and its cousin the Propeller can be found in consumer electronics stores all around the country. Parallax has a wide variety of premade sensors for use with the STAMP or Propeller. Some sensors include: GPS, Accelerometer, Color, Compass and Pressure sensors. They also have a stunning array of robotics kits and parts. Truly, enough to get you started and then some.

[Parallax Starter Kit](#) (Intelligent Circuits The Easy Way)

[Boe-Bot Robot](#) (Step It Up With A Bot)

[SumoBot Robot](#) (A Robot Built For Fighting)

The Microchip PIC

The Microchip PIC bridges the gap between the hobbyist world and the professional world. Microchip offers the largest variety of microcontrollers (a microcontroller is a processor with on-board memory) with all different kinds of functionality. The reason the PIC is a popular choice for being the brains of a project is because there are so many resources available to help with design. Microchip has hundreds of example application notes for the many features that each microcontroller offers: Analog to Digital Conversion, Timers, USB 2.0 and many other features. A downside to the Microchip PIC is that since it is not specifically tailored towards hobbyists, you cannot find combo kits with many parts inside, you have to design the entire robotic system from beginning to end.

[PICKit – Programmer and Development Board](#) (Great For Starters)

[Experimenter’s Board](#) (Get This Next)

[Module Board For Pro Experimenters](#)

Analog Madness

Taking a break from the digital world and coming back to the old way of thinking there is Analog Design. Since analog electronics were the first type developed, a wealth of example designs exist and their simplicity and low cost is at times hard to believe. This is the main advantage of analog designs, the parts are cheap, and so the designs are cheap to build.

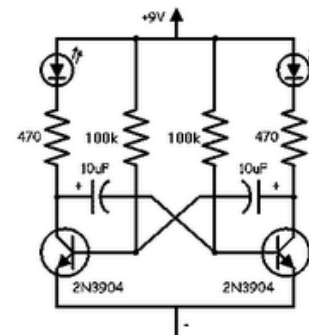
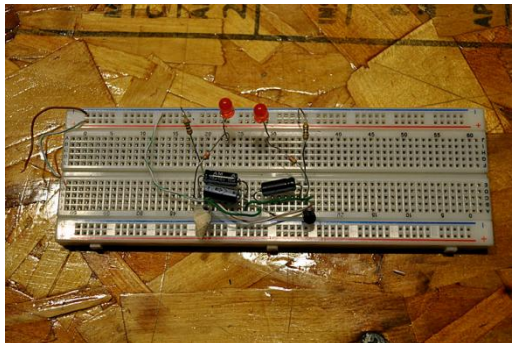









To make a quick example, above you can see a classic analog circuit. The dual blinking led circuit. This circuit uses a normal 9v battery, two LEDs (\$0.10 each), two transistors (\$0.05 each), 2 capacitors (\$0.15 each) and four resistors (\$0.05 each). In total, there are 11 parts with the most expensive part being the 9v battery. This is a dirt cheap design and it will last forever and ever until the battery dies or the parts go bad. The digital equivalent of this circuit would be more expensive to make and would drain the 9v battery quicker than the analog equivalent.

Chapter 6 – A Project Anyone Can Make (Flashy Things)

The first project that I want to introduce you to on the electronics side is the dual LED blinker circuit (scientifically known as an astable multivibrator circuit). This is an analog circuit that has a long history because of its unique property of being able to turn off and on at a pre-determined time interval. If we add 2 LEDs to the circuit, the circuit will blink the two LEDs back and forth.

What You Need To Build It

Below is a parts list of quantity/value/component type for the dual LED blinker circuit. I have also given you some links to where you can find the parts.

Quantity	Value	Component Type	Circuit Symbol	Available At...
2	220k Ω	Resistor		Jameco
2	240 Ω	Resistor		Jameco
2	1 μ F	Capacitor		Jameco
2	2N3904	Transistor		Amazon
2	Green (3mm)	LED		Jameco
1	9 Volt	Battery		Amazon
1	35 Watt	Soldering Iron		Amazon
1	60/40	Solder		Amazon

What You Are Building

At the end of chapter 5 I introduced you to a simple analog design, which is actually what this project will be building. However, I want to go through the process of explaining a circuit diagram to you, how to read it and what is represented in it. Whether or not you already have experience with circuit diagrams, take a look through to refresh your memory.



This symbol represents a **Resistor**. The value of the resistor is usually written nearby.



This represents a **Capacitor** in a circuit, with the + side identified for clarification.



This is the symbol for an **LED** in a circuit. The arrows mean light emitting.

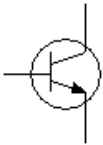

This symbol represents an **NPN BJT Transistor**. The arrow pointing out is the 'Emitter' Pin, the center pin is called the 'Base' and the pin on top is called the 'Collector'.



This represents a **Ground**. The flow of electronics goes from positive to this ground.

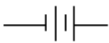

This is the symbol for a **Battery**. The long bar (on the right side) represents the positive end. The short bar (on the left side) represents the negative end of the battery.

Now that you have some basic knowledge of how to represent circuit elements, I will show you a way to organize the circuit together and connect the elements with lines representing wires.

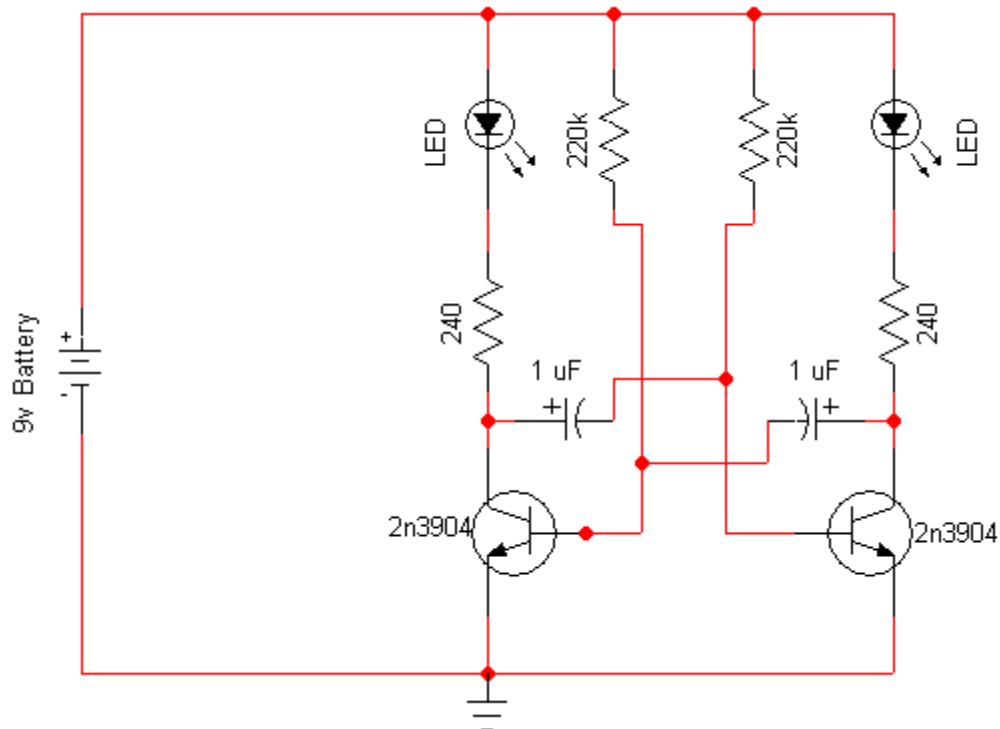

Each wire connection is represented with a red colored wire. The red circles seen at some points, represent a point where more than 2 circuit elements are being connected together.

Following this notation when drawing circuits is extremely important because it is how electrical engineers understand circuits and expect other people to draw things out. As you learned earlier in this book, the flow of current will start at the + side of the battery and go through all the elements to the ground or – side of the battery. Exactly how the flow occurs is what makes each circuit unique and in this circuit it is turning the LEDs on and off. Believe it or not, this circuit is actually fairly complex and even in college it is not explored completely until the second or third year of an electrical engineer’s study. Because of that, I will point you to this article that explains the astable multivibrator and for the sake of this E-book I will say let us just have fun and build something simple and cool.

How You Build The Circuit

At long last, the fun can begin! Start by organizing all your parts on a table so that they are easily recognizable and you won’t get them mixed up. Below I have a picture that identifies what each part looks like paired together.

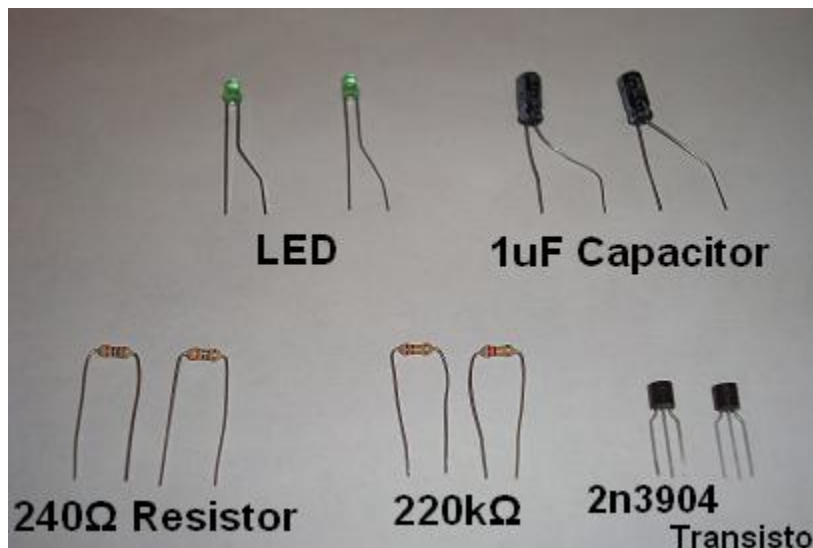

Before any connections are made or soldering is done, you will need to warm up your soldering iron for a few minutes and get it hot. Get your solder ready as well and look only at the two transistors.

First bend the Emitter pin of each transistor so that it is straight and 90° from the other pins. To the right is a picture of the 2n3904 transistor with each pin labeled. Below you can see the first step before and after. After bending both of the E pins solder them together to make the first

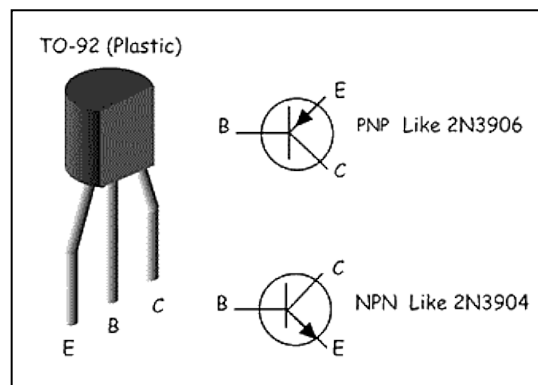

connection. The three pictures below show the pins bent and then soldered to connect them together.



Now you are going to connect the 240Ω resistor (color on top of it is Orange, Blue, Brown) to the C or Collector pin of the transistor. The first picture is before soldering and the second picture is after. This will make the circuit look like two T's with gigantic arms.



The next step is to connect the 220kΩ resistor to the B or Base pin (middle pin) of the transistor. Again, use your soldering iron and solder them together. Be careful not to hold your soldering iron on the transistor's pins for too long, or you might burn them.

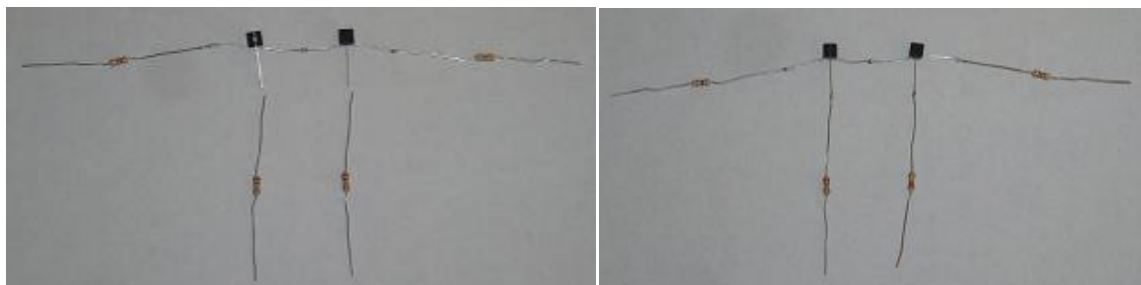

220kΩ Resistors Placed

220kΩ Resistors Soldered

The circuit is half-way done! The next step is to solder the capacitors to the circuit. This is a trick step because one capacitor solders onto the top and the other onto the bottom of the circuit. To get a better idea of how this should turn out, take a look at the pictures below and they will guide you. The reason the capacitors are not connected to the circuit on the same side is because they would be too close together and would likely touch other wires making bad or unintended connections.



First Capacitor Placement

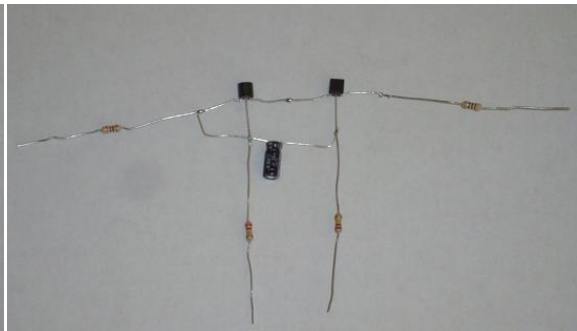

Second Capacitor Placement

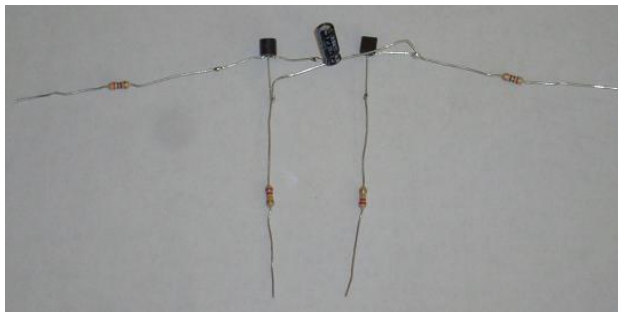

First Capacitor Soldered



Second Capacitor Soldered

At this point the only thing left to connect to the circuit are the two LEDs. They need to be soldered to the 240Ω resistors. Like was done with the other parts, bend the pins horizontally and then solder them to the circuit.

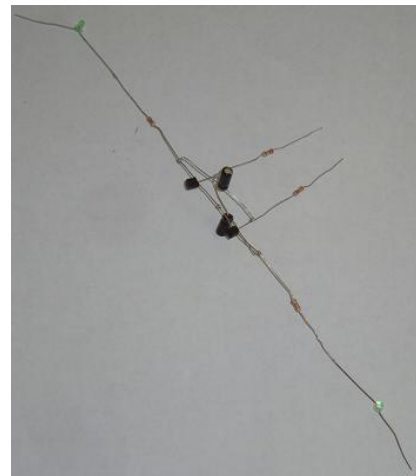
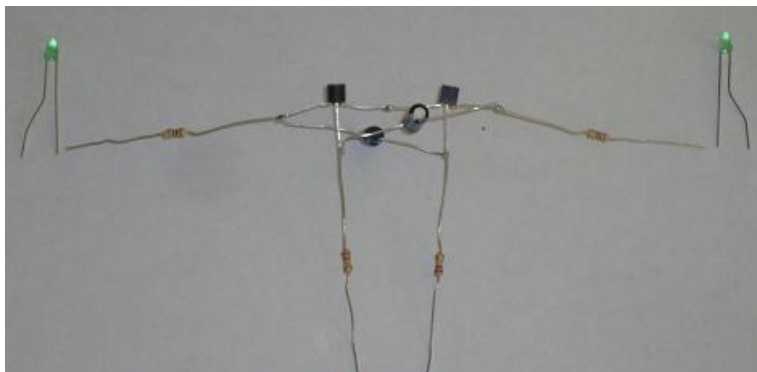

One final solder point is all you need to do and then you are done. First, start bending the pins in a curved fashion. 4 wires are going to need to be soldered together so it will take a little effort.

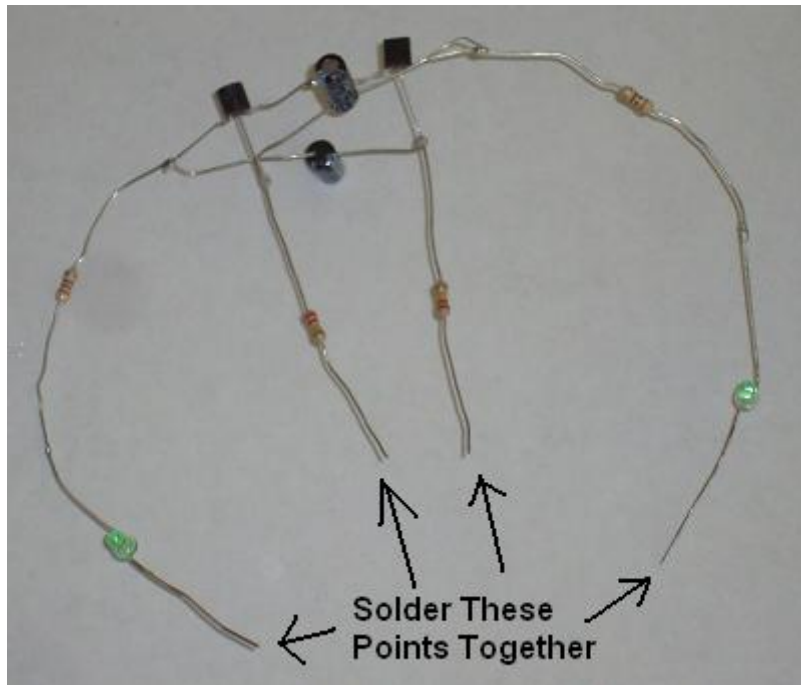

Once the four points have been soldered together, the circuit is ready; you only need to connect it to a battery. I suggest using a 9v battery because then you can mold the circuit around the battery in an artistic looking way. The only requirement when bending the wires in to shape is that you must be very gentle and careful and make sure these two points in the circuit touch the battery:

The four pins that were soldered together in the last step of building the circuit need to touch the + or positive side of the battery. The first step of the circuit where the two transistor's E pins are connected needs to be touching the - or negative side of the battery.

As you have probably figured out this isn't the typical way that circuits are wired up and powered by a battery, but the point of this first project is fun, not seriousness.

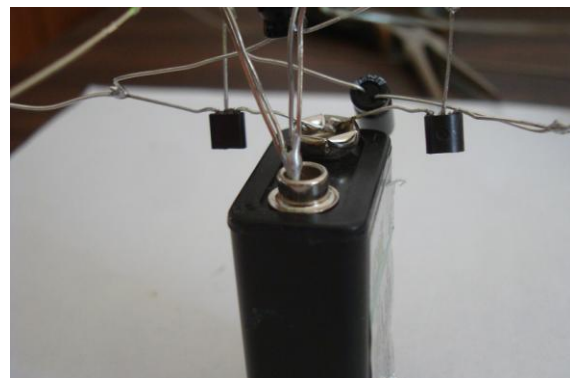

After a few minutes of bending things every which way to get them balanced and lodged into the battery's + (positive) and - (negative) points here is what the design I made looked like. Yours can be and probably is different, which is ok as long as it works!

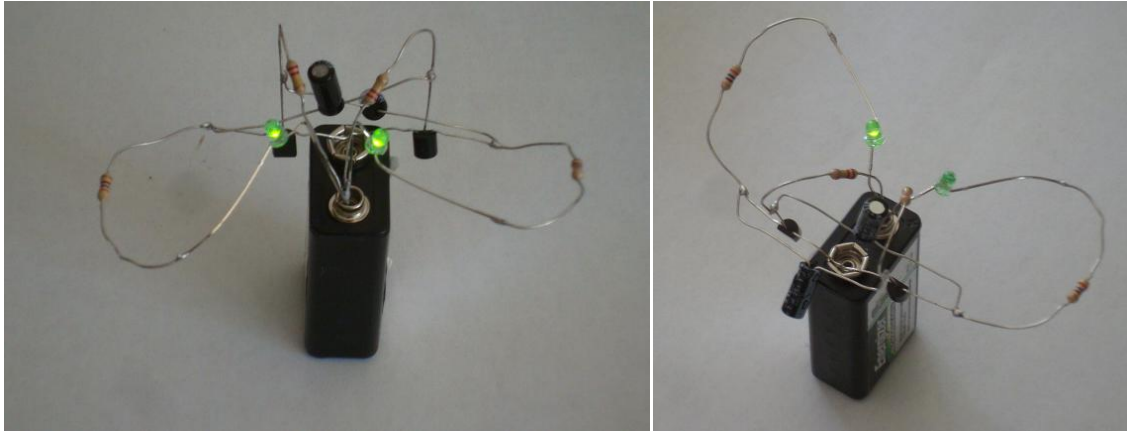

It Works! What Now?

Now that it works, celebrate, show it to someone! Completing a project like this, as simple as it is, helps you develop the skills you will need when you start to move to more complex projects in robotics. Since electronics is the heart of any robotics system it is important to get a solid foundation and understanding.

By doing this project you learned about some of the basic parts in electronics: what they look like, their different values and their symbols. You looked at an electric schematic and distinguished the different parts inside. Most importantly, step-by-step you built it and it worked. Believe it or not, but this process is the same for any robot that you are going to build. The only differences that will exist are in exactly what your robot does and that will be up to you!

Chapter 7 – Case Study: Build Your First Robot

Building your first robot will be one of the most enlightening experiences you can have. This is because you will always remember the first one you built, how it worked and how other people were impressed by its simplicity and functionality.

The type of robot I will explain and build with you throughout this chapter is called a line-follower. Line-following robots have been around for a long time because their design is simple but very effective. The way this type of robot operates is simple: the robot follows a black line drawn on a piece of white paper or poster board. If the robot senses white or black ahead, it will either turn on the left motor or the right motor. This means that the robot actually turns back and forth and never goes directly forward. However, since the sensing of black and white by the robot happens so fast, the illusion of moving forward is created and the robot follows the line.

In this chapter I will explain the basic theory behind the 3 main functions of the electronics, the physical build process and the parts necessary for this project. While reading this chapter I urge you to remember that building a robot means knowing where to get parts that fit together to solve your problem. You cannot always start from scratch, sometimes you just need to use premade parts because making your own would be far too time consuming. With that in mind, get started building!

What You Are Building

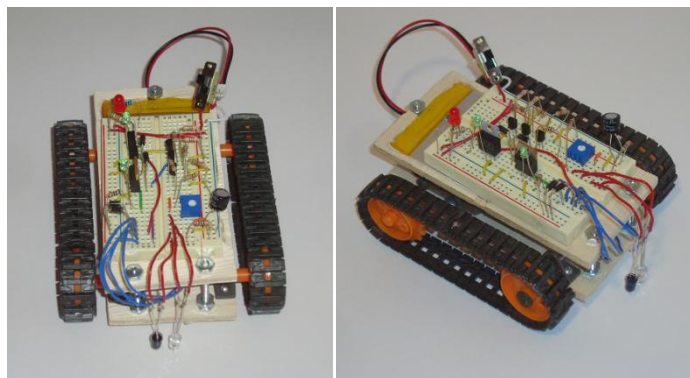

If anything about the above picture does not look in some way cool or intriguing to you about how it works, what it does and if it even works, do yourself a favor and Stop Reading!

So that very DIY looking mini-tank is the outcome of this project. It has 3 main parts that make it work. The first part is what tells the robot the difference between white and black. It consists of one infrared (IR) emitting LED (this is basically like a miniature black light) and one phototransistor which senses infrared light.

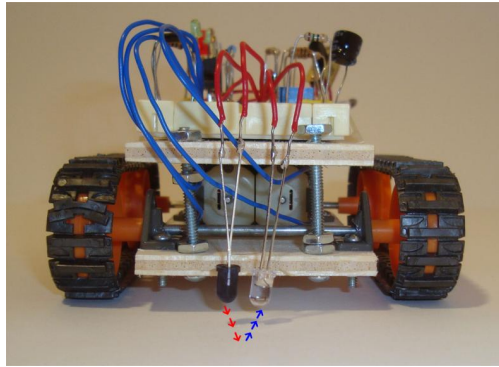

The way these two devices work is simple. The IR emitter (darker looking LED) shines infrared light onto whatever color and the phototransistor senses reflected light. Depending on the color reflected to the phototransistor, it will output a lot or a little electricity.

The next part of the line-following mini-tank is the motors and motor driving circuit. As seen above the motors are two small 3v motors that drive each side of the robot.

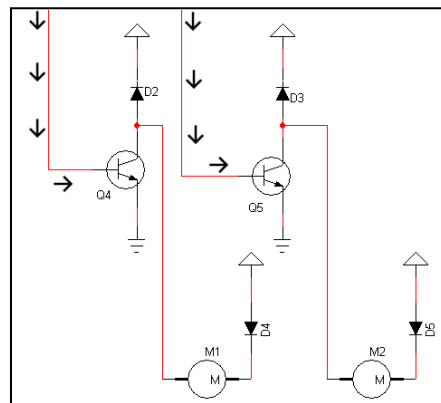

The circuit seen above is how each motor is turned on. Again, the entire circuit depends on whether white is detected or black is detected by the sensors, so naturally we only need two different states.

State (1):	motor 1 - on		motor 2 – off
State (2):	motor 1 – off		motor 2 – on

Depending on which state you want, a positive voltage needs to be applied to the 'Base' pin of Q4 or Q5. A positive voltage on Q4's base pin would force State 1, because that would turn the transistor on and allow current to flow through. Similarly, a positive voltage on Q5's base pin would allow current to flow through motor 2. If some of this terminology does not make complete sense to you at the moment, do not fear, just keep reading and you will you learn!

The last portion of the robot is the "brain" part that tells which motor to turn on. The circuit below is what connects the black or white sensing part of the robot to the motors.

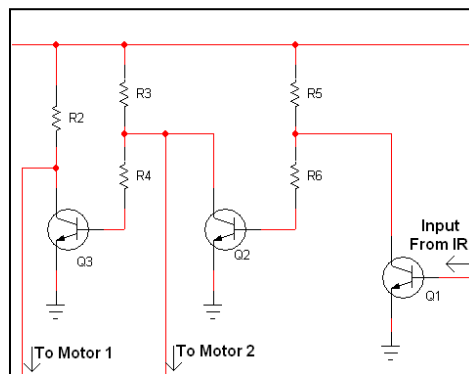

It looks a little complicated at first glance and even at second glance, but I will walk you through it. Just like with the motors, there are two different possible states:

When the IR LED and Phototransistor sense black, Q1 is not turned on because no voltage is applied to Q1's Base Pin. Therefore, a few other things happen: Electricity can flow through R5 and R6 to turn on Q2, which means no voltage is applied to Q3's Base Pin which turns Motor 1 on and Motor 2 off.

When the IR LED and Phototransistor sense white, Q2 is turned on because a voltage will be applied to Q1's Base Pin. What happens next is opposite the previous state: Electricity cannot flow through R6 which means a voltage cannot be applied to Q2's Base Pin, Q2 is off. This means electricity can flow through R3 and R4 which turns Q3 on and turns Motor 1 off and Motor 2 on.

Phew! That is a ton of theory jam packed into a few short sentences. Do not worry about understanding every small concept and explanation above, as you progress and build this robot more and more will become clear to you. I just figure if we get the theory out of the way, we can focus more on the fun stuff!

What You Need To Build The Robot

With the theory under your belt and in the back of your mind you can move on to looking at the parts. There are two different types of parts for this project and some of them do overlap: Mechanical and Electrical parts. The mechanical parts are anything that doesn't conduct electricity; gears, wood & screws for example. The electrical parts are anything that does conduct electricity; resistors, breadboards & wires are some examples. Both types of parts are needed to get this project working, but they come from different places.

The parts listed in the [appendix](#) include every single part used to build the project for the line-following mini-tank, nothing is left out. Also, I have linked to places where you can find these parts to make it easier for you. Below I will run through the different types of parts used to build the mini-tank robot and explain their basic purpose.

[Resistors](#)



The most basic element in the design is the resistor. 5 different types of resistors are used in the circuit design for the robot. The purpose for the resistor in all cases is to limit the flow of electric current through the wire. The low value of 15Ω before the IR Emitter LED for example, allows a lot of electric current to flow so that the IR LED is super bright. The other resistors at $10k\Omega$ are used primarily for the decision making process (white vs. black sensing) and a lot of electric current is not necessary.

[Diodes](#)



Three different types of diodes are found in the circuit. 3 standard LEDs are used to show you if power is connected and which motor is active. The second type, 1N4001 are used to allow or impede the flow of electric current. The last type is the IR Emitter LED. This LED shines the bright IR to the sensor.

[Transistors](#)

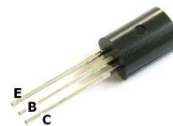

Two types of transistors are used. The first type is the standard 2N2222. This transistor is a standard "NPN" type transistor. We use it as a simple electric switch. If a voltage is applied to the base pin, it is turned on, otherwise it is turned off. The second type of transistor used is the TIP120. These are also "NPN" type transistors, however they are high power for driving motors.

Capacitors



One capacitor is used in the circuit and its main purpose is to help stabilize the power supply to the circuit as well as to the motors. The large value of $47\mu\text{F}$ means the voltage should remain fairly stable across the entire circuit.

Jumper Wire



Since the design is going to use a breadboard, jumper wire will be needed. Jumper wire is used to make the point to point connections on the breadboard. They will also be used to connect the motors, IR Emitter and Phototransistor to the breadboard. This type of wire is specially made for breadboards and fits perfectly.

SPST Switch (Optional)



Single Pull Single Throw. This is a standard power switch. It is optional, however I recommend putting one between power and the battery. Being able to turn off the mini-tank with a switch instead of pulling out a wire is far easier.

Breadboard

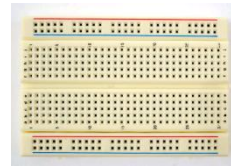

The breadboard is affixed to the top part of the mini-tank. It holds and connects the entire circuit together. Breadboards are commonly used for electronics prototyping. The middle holes of a breadboard are connected together horizontally with a plate underneath and the side power and ground holes are connected together vertically.

Mini Tank

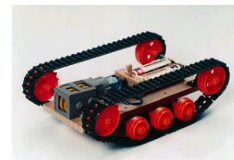

The tank treads used in this project came from this Tamiya Tank Kit. It is the basic mechanical building block of this project. Other wheels could be substituted but it would take away from the cool look of the tank platform.

Twin Motor Gearbox



Because the mini-tank needs the ability to turn left and right, a twin gear box is used. The Twin Motor Gearbox made by Tamiya is used for this. It fits perfectly with the Mini-Tank kit so it is an ideal choice.

LiPo Battery



A flat Lithium Polymer (LiPo) battery is ideal for any small project. They pack a large punch and are very small in size. This type of battery can be a little unstable, so Lithium-Ion might be better for people who are a little paranoid.

Plywood



The base of the mini-tank is a small piece of cut and drilled plywood (5.2mm width). Two pieces are used, one for the base and one for the roof. Plywood offers a simple and sturdy platform for prototype projects.

Nuts and Bolts



4-40 and 6-32 size bolts are used in this project for mounting the gearbox to the base and for holding the roof steady above the gearbox. The gap between base and roof is 1.25”.

How The Robot Works

Explaining exactly how this robot works is not easy. Trying to understand the many things that are happening at the same time can cause your brain to overflow, so I will break things up into smaller pieces, which is what you should always do when looking at a big issue.

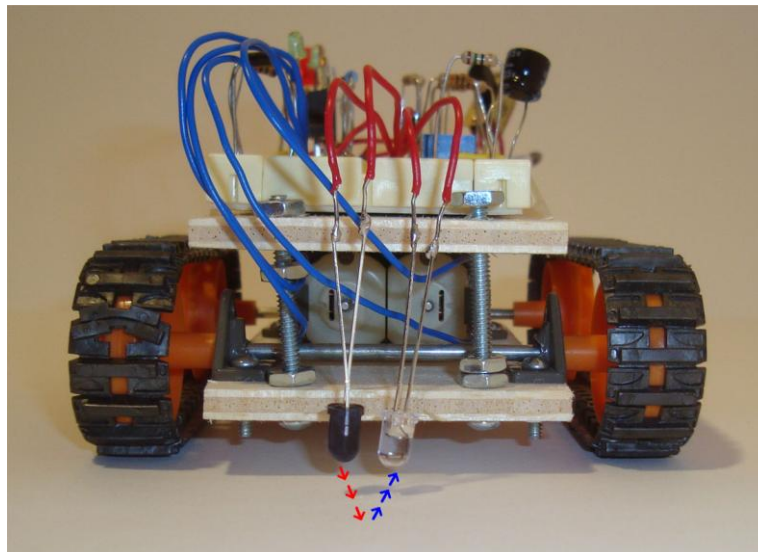

IR LED Emits And Phototransistor Receives

The picture above shows the front of the mini-tank line follower. The IR Emitter is the LED that looks black and the Phototransistor is the LED that looks clear. The way they work together is one shines light and the other receives the reflected light just as the red arrows in the picture above demonstrate. Different surfaces and different colors have different amounts of reflectivity. The two different colors we are worried about are black and white.

When the IR emitter shines on black color, the light is absorbed and nothing is reflected to the phototransistor. When that happens, the phototransistor stays off and does not conduct any electricity. Since nothing changes in the circuit, the left motor stays on. However, when the IR emitter shines on white color, the light is actually reflected and the phototransistor is turned on. This allows for electricity to flow and tell the rest of the circuit to turn the right motor on.

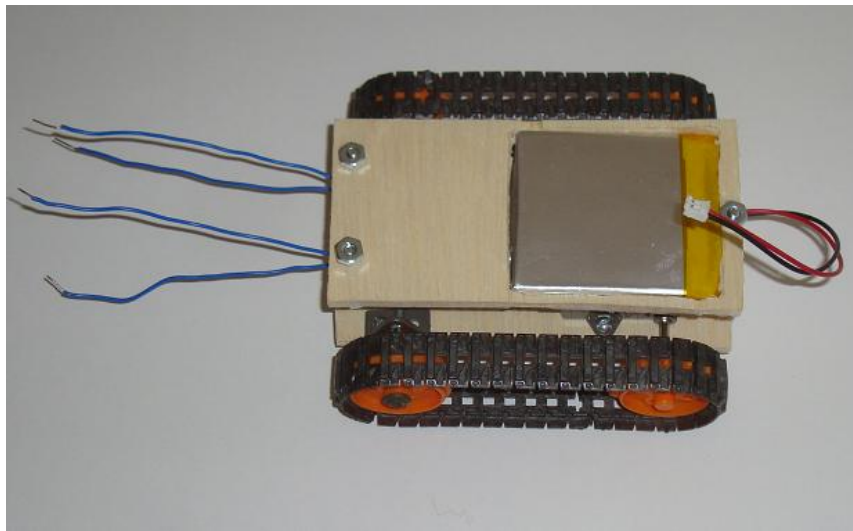

The Mini-Tank Without Electronics

The mechanical design of the tank is also very important. The design used here is very square making it so that with proper control the tank could turn 360° without moving forward or backward. This type of a design is good because the robot we are building will be doing nothing but turning left and right in search of white or black ground.

The gearbox also helps hold up half of the roof of the robot which makes the breadboard that we will put on top of it more stable. The nuts and bolts used in the front hold it sturdy as well. The one bolt used in back is only for keeping the battery in place and a little extra support. Feel free to modify design to add more or less supporting bolts and nuts.

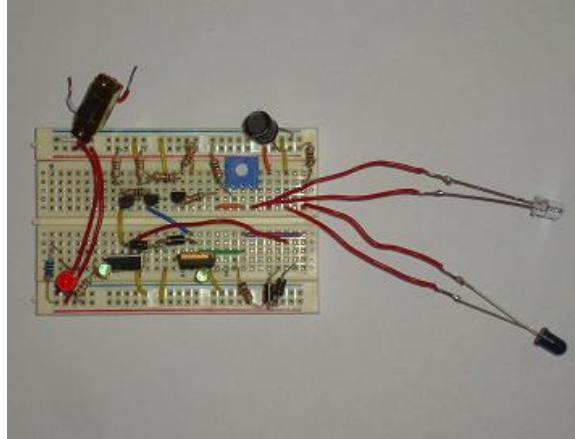

The picture above shows the entire circuit of the mini-tank line follower robot. It looks more complex than it really is. In total there are 30 electric components on the breadboard and the circuit diagram for how they are connected together is shown below.

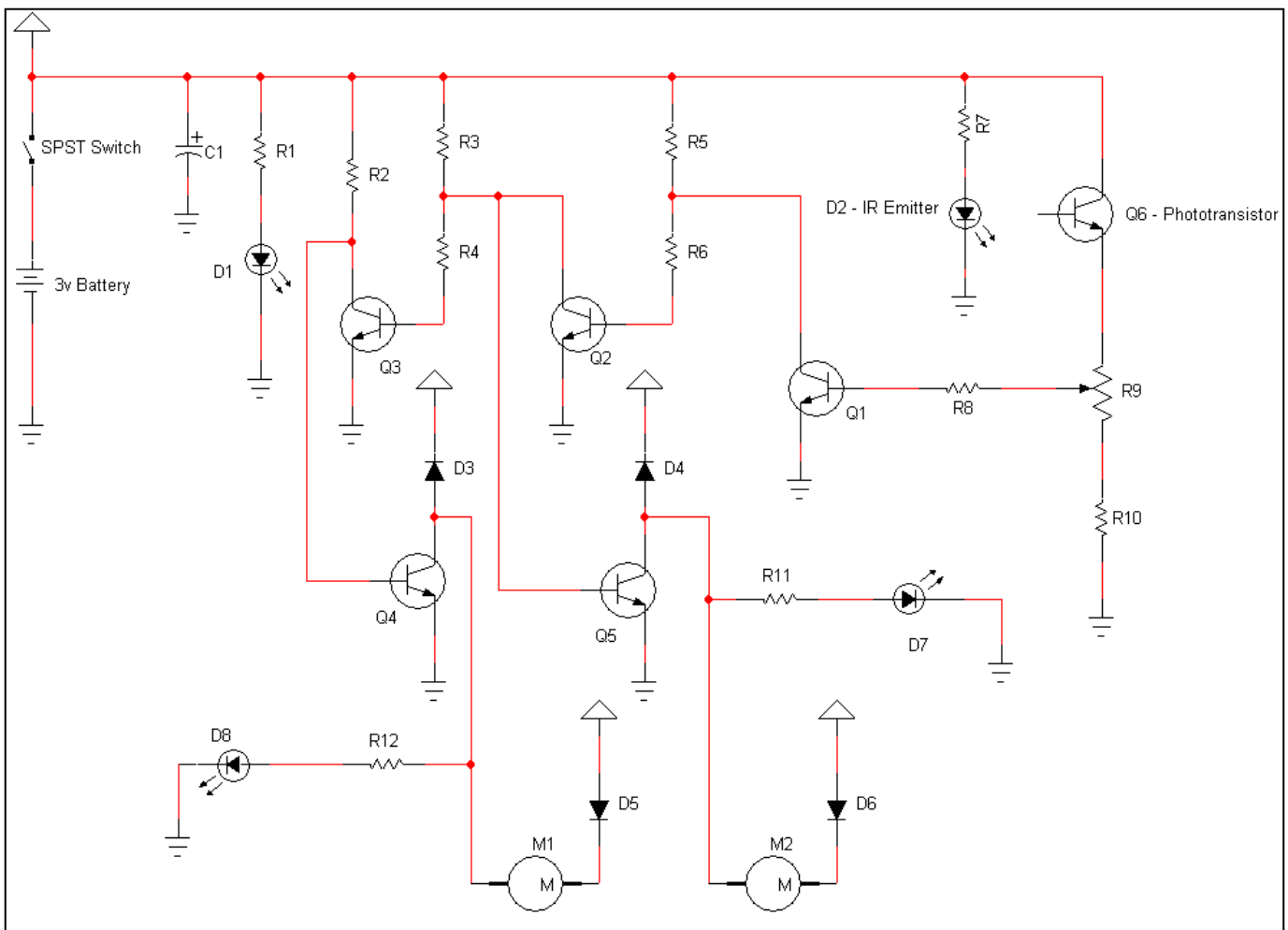

The Mini-Tank Line Follower Circuit Diagram

For hobbyists who are just starting out in robotics, the circuit probably looks daunting and it is. However, take things slowly, experiment and you will make progress and be able to build this robot start to finish. The key is researching, experimenting, asking questions and getting answers to learn what does what and where.

How You Build The Robot

Now the real fun begins! You have already run through the theory and background so now it is time to dive into the experimenting and building. This part will be separated out into two sections: the mechanical building instructions and the electrical building instructions.

Building The Mini-Tank (Mechanical Instructions)

The mechanical design of the tank is actually not much more than two pieces of wood along with some holes drilled for assorted nuts and bolts. The first two things you need to have prebuilt are the gearbox and the mini-tank treads.



The Mini-Tank: Mechanical Parts

Once you have completed those components you can move on to cutting the plywood. The base and the roof of the mini-tank robot are the same size: 6.2cm width x 12cm length. I used a

standard jigsaw to cut the pieces. I wanted the battery to fit snugly inside the roof so I also cut out a 5.3cm width x 6cm length piece from the roof. Now the battery had a place it could go without taking up extra space.

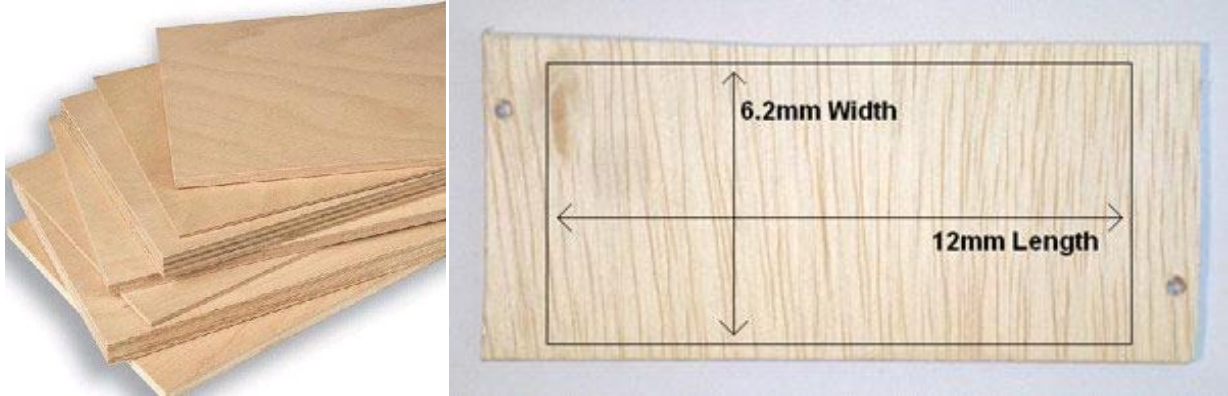

With the pieces cut the holes needed to be drilled into each piece to hold the gearbox and tank treads steady. Below I mapped out the location for each hole drilled. The drill bit used for all holes was a 5/32" bit.

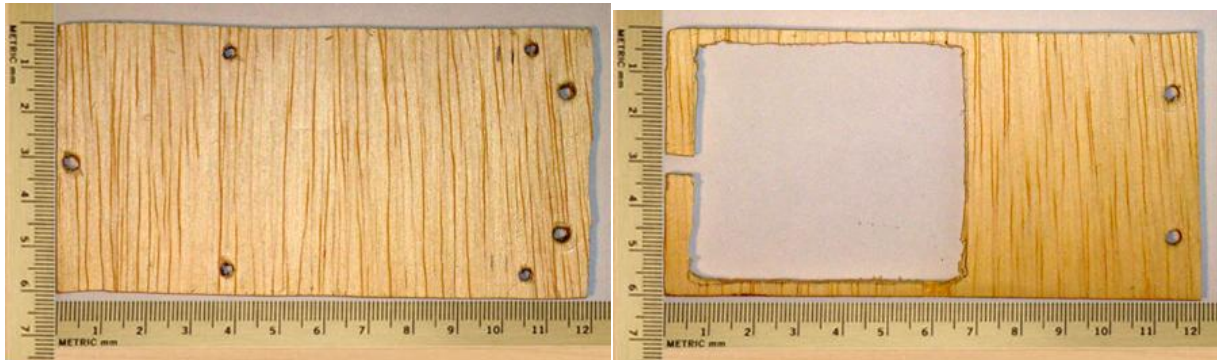

The Mini-Tank Base With Measurements

The Mini-Tank Roof With Measurements

Now the mini-tank robot can be assembled. 1.5" nuts work well for base and roof support while 0.5" nuts worked well for holding the motor and treads in place.

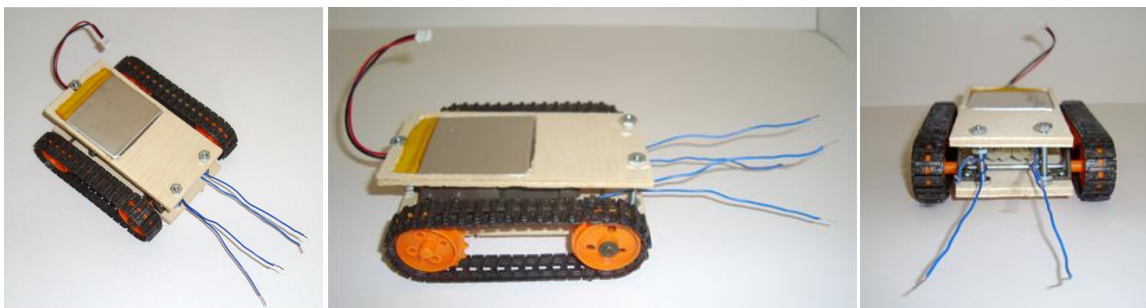

Building The Mini-Tank (Electrical Instructions)

Before starting to connect everything together, make sure you have a copy of the circuit diagram nearby. That diagram is a map of how everything is connected together and should be your reference whenever you have a question about what goes where.

Let us begin! Put all your parts out in front of you. I like to put them on a white piece of paper so they are easily identifiable.

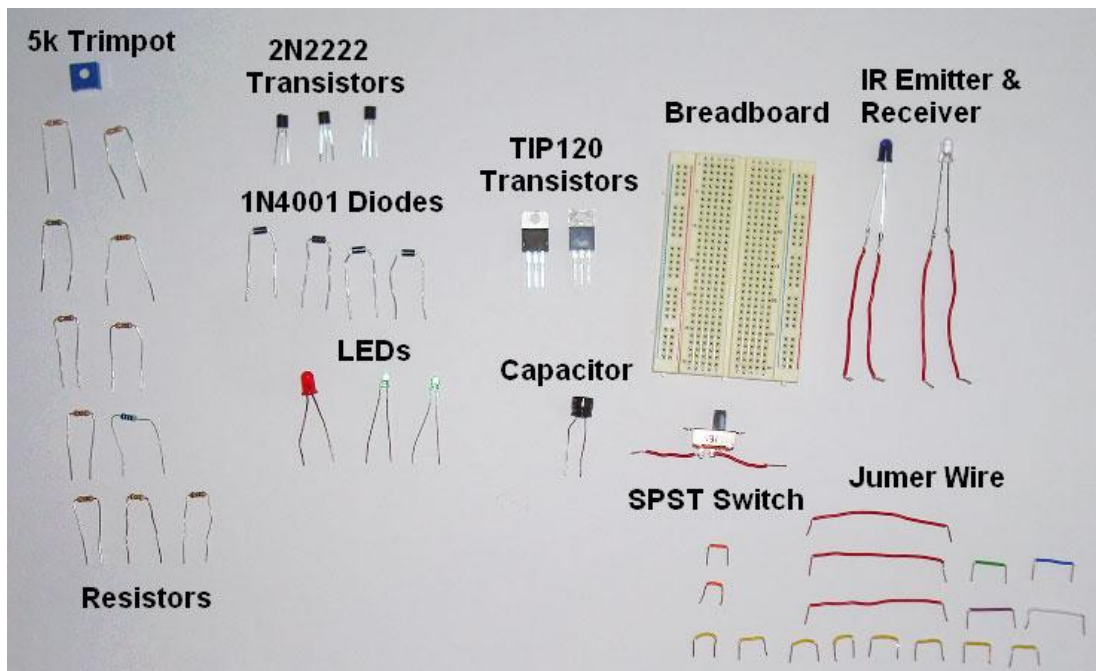

The Mini-Tank Electric Parts

The first thing to assemble together is the power circuit and the red led indicator light. You will need parts: R1 (330 Ω), D1(Red LED) and C1(47 μ F). First I soldered some jumper wire onto the SPST Switch and then assembled the circuit. When the battery is connected the red LED is on.

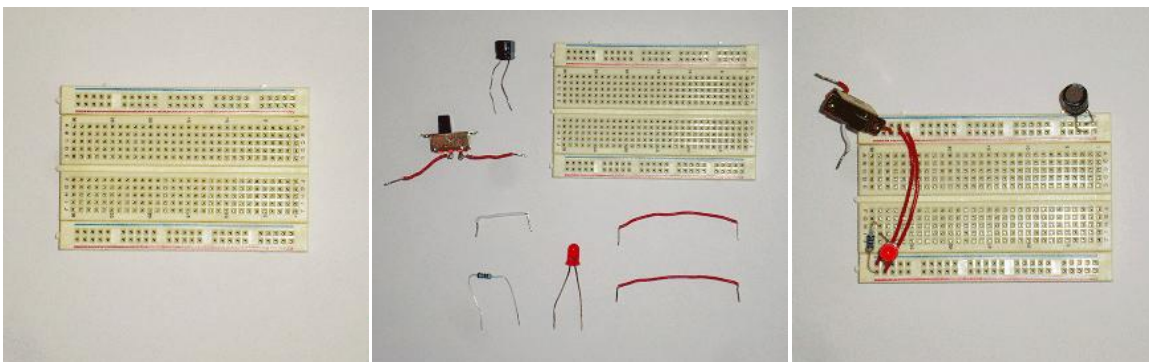

Now it is time to assemble the IR Emitter LED and Phototransistor part of the circuit. You will need parts: R7 (15 Ω), R8 (10k Ω), R9 (5k Ω Potentiometer), R10 (1.5k Ω), D2 (IR Emitter) and Q6 (Phototransistor). Connecting these on the far side of the breadboard will be best, since the Emitter/Phototransistor will need to be in front of the robot. I chose to solder some jumper wire onto the Emitter/Phototransistor for some added length.

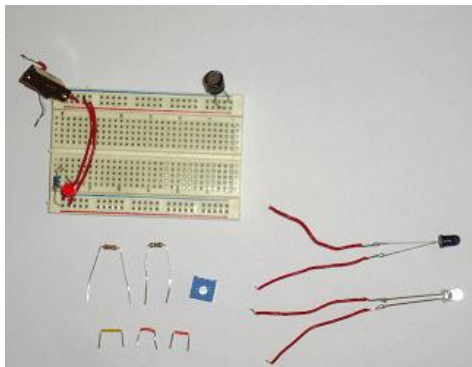

Parts For IR Circuit

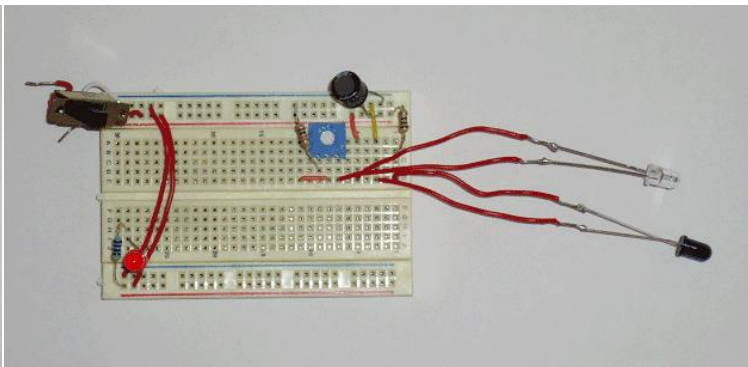

IR Circuit Assembled

The next step calls for wiring up the brains. This portion of the circuit is what tells which motor to turn on or off. You will need parts: R2 (360 Ω), R3 (360 Ω), R4 (1.5k Ω), R5 (10k Ω), R6 (10k Ω), Q1 (2N2222), Q2 (2N2222) and Q3 (2N2222). 3 resistors connect directly to the power and the other 2 go to the transistors. A few interconnections are also made with short jumper wires.

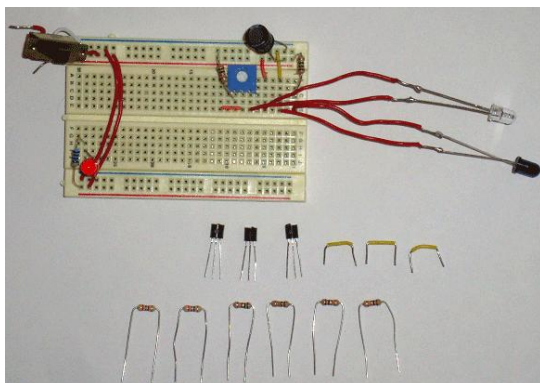

Parts For "Brain" Circuit

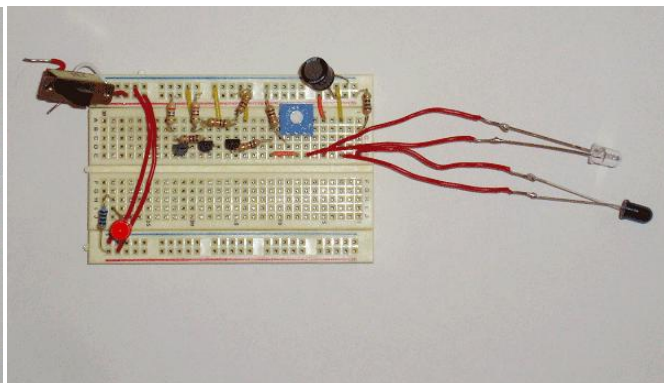

"Brain" Circuit Assembled

Almost done! The last part of the circuit is the motor driver. The parts you will need: R11 (150 Ω), R12 (150 Ω), D3 (1N4001), D4 (1N4001), D5 (1N4001), D6 (1N4001), D7 (Green LED), D8 (Green LED), Q4 (TIP120) and Q5 (TIP120). I put the two big transistors in first and then connect all of the diodes where they are supposed to be. Then the LEDs and resistors are put in and lastly the 4 blue jumper wires soldered to the motors are connected. Done!

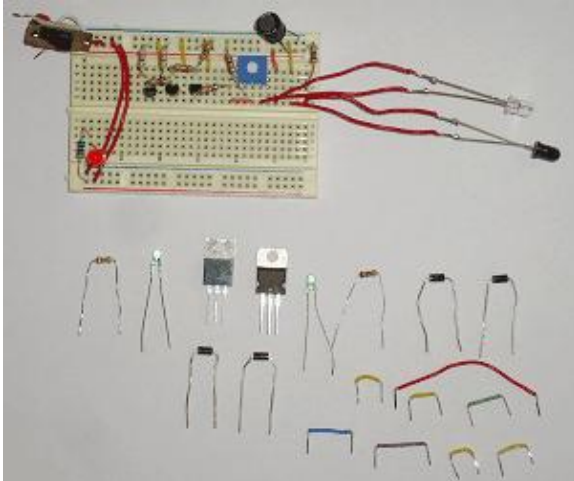

Parts For Motor Control Circuit

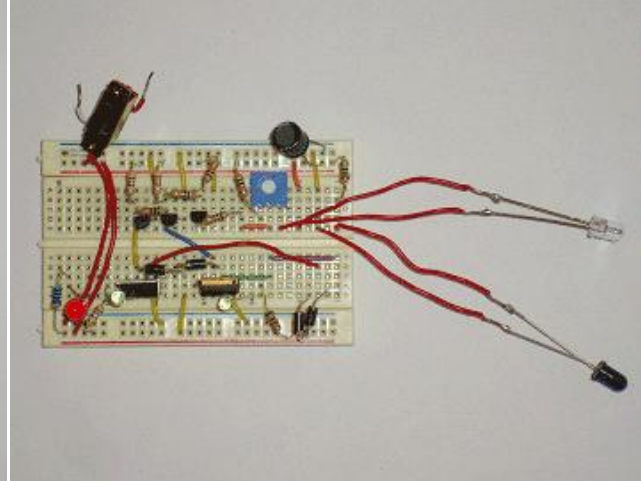

Motor Control Circuit Assembled

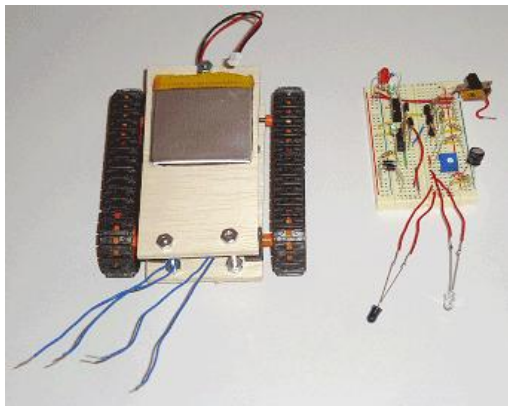

Circuit & Mini-Tank

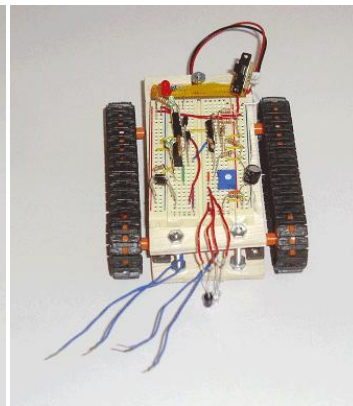

Circuit on Mini-Tank

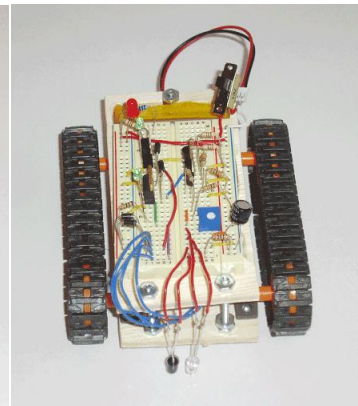

Motors Connected

The Robot Works! What Now?

Hands down the most fun part of any project is when it is working. There is no longer any frustration, only joy of watching your creation work its way up and down a pathway. The mini-tank line follower is very redundant and will work across many different surfaces.

While experimenting with your new robot you will find that you can use it on kitchen counter tile, light colored floor, even on pavement! As long as the surface will reflect light, you can put down some black electrical tape and the robot will follow it forever.

To give you an idea of how the robot should work in case you have something wired incorrectly, or if you just need a little motivation, I made a short video for you. Below is a link to the YouTube video I made of my Line-Following Mini-Tank going around a figure 8 track.



[Click To Watch The Mini-Tank In Action](http://www.pyroelectro.com)

For line following robots, the true test is having different lines for the robot to follow and seeing how well they react to different 'courses'. The best thing to do once your robot is ready is to buy 2 or 3 large white poster boards. With these posters draw 'courses' on them for your robot to follow. Figure 8's will work for your first line follower course; you might be surprised how your robot goes about following the black line. Here's another example of one you could make:

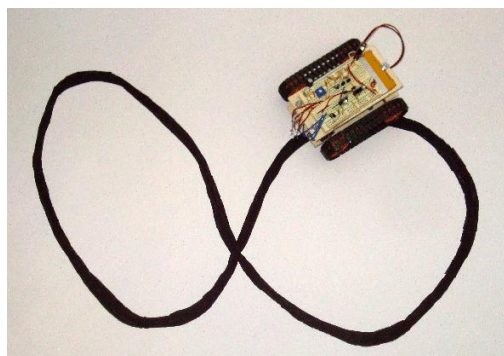

Mini-Tank on a Figure 8 Track

The next thing that is important after you have finished building the mini-tank line follower is being confident that you understand how it works. The mechanical side of the build process is fairly straight forward; however the electrical side is far more complicated. Go through the theory of how it works a few times until you understand the circuit. Having a solid understanding of the electronics involved will give you a pathway to building your own similar and better robots, especially once you make your way to the digital side of robotics.

Chapter 8 – The PyroElectro’s Story

I started PyroElectro dot Com in 2007 to keep track of all the projects that I had completed. Slowly, I built up a repository of circuit diagrams and code for when I needed them again. I noticed other people really took interest in what I had done and they were glad to see examples with working code and schematics. I continued posting a ton of tutorials and projects in an effort to help out beginning hobbyists around the world and I still do today!

University Life

In my youth I was surrounded by computers, electronics and the madness that lead up to the dot-com bust in 2000-2001. E-bay, Google, Yahoo, PayPal and the other big named HQ’s had all moved into my hometown by the time I was in high-school and they all grew rapidly. Being in that environment really stifled the engineering side of me. Electronics became second nature and naturally led me to start studying electrical and computer engineering at university.



[The Wooden Menace](#)



[Short Range Personal Radar](#)

At university I began like everyone does as an undergraduate. I learned a lot more of the theoretical side of the analog and digital electronics worlds which built my fundamental base of knowledge. College life was typical for me. Some professors were awesome and made me want to pursue a professional career in teaching. Other professors were just downright terrible and made me want to get out of there as soon as possible. Many days were a back and forth of this nature. Still, I managed to graduate after studying engineering for my 4 years.

After I finished my undergraduate studies I continued on to pursue graduate school with an electrical engineering focus. Even though going for a PhD sounded tempting and tuition would have been paid for I stopped short and left school after finishing my M.S. Electrical Engineering.

Professional Life

The time comes in everyone's life when they are forced to grow up and join the real world. When this moment hit me, I was lucky. Having many options is something that the unemployed rarely enjoy. Hard work and persistence creates this type of opportunity.

My first job out of college was with NASA's Jet Propulsion Laboratory. The project they were working on at the time was the Mars Phoenix Lander and also the new Mars Science Laboratory. Working on robots meant to go into space and onto another planet is complex beyond what you could imagine. The number variables are out of control. However, when you have the brain power that exists at JPL it is something that can be accomplished. The Phoenix landed and completed its mission confirming that there is water on mars! After leaving my work at JPL I pursued jobs working for various smaller companies doing consulting working on projects.



[The Autonomous Drifter](#)







[The Personal G-Force Meter](#)







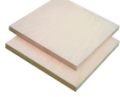

The professional work I have done has been on all different sides of the digital and analog spectrum. I have done work that varies from high speed board and ASIC design to digital FPGA or microcontroller system designs. However, if I had to choose I would pick verilog/vhdl FPGA work as being my favorite area to be. I hope you enjoyed my E-book and please visit [PyroElectro dot Com](http://PyroElectro.com) to see what is new.

Appendix

Mechanical Parts

Picture	Part Type	Name	Available At...
	3.7v Lithium Polymer	Battery	Sparkfun
	Tamiya Kit	Twin Gearbox	Amazon / Jameco
	Tamiya Kit	Tracked Vehicle Chasis	Amazon / Jameco
	#6-32 and #4-40	Nuts and Bolts	Amazon
	6.2mm x 12mm	Plywood	Amazon

Electrical Parts

Picture	Schematic Name	Part Type	Value	Available At...
	R1	Resistor	330Ω	Amazon / Jameco Parts Express
	R2	Resistor	360Ω	Amazon / Jameco Parts Express
	R3	Resistor	360Ω	Amazon / Jameco Parts Express
	R4	Resistor	1500Ω	Amazon / Jameco Parts Express
	R5	Resistor	10000Ω	Amazon / Jameco Parts Express
	R6	Resistor	10000Ω	Amazon / Jameco Parts Express
	R7	Resistor	15Ω	Amazon / Jameco Parts Express
	R8	Resistor	10000Ω	Amazon / Jameco Parts Express

	R9	Potentiometer	5000Ω	Amazon / Jameco Parts Express
	R10	Resistor	10000Ω	Amazon / Jameco Parts Express
	R11	Resistor	150Ω	Amazon / Jameco Parts Express
	R12	Resistor	150Ω	Amazon / Jameco Parts Express
	D1	LED	Red (5mm)	Amazon / Jameco Parts Express
	D2	LED	IR Emitter (5mm)	Amazon / Jameco
	D3	Diode	1N4001	Amazon / Jameco Parts Express
	D4	Diode	1N4001	Amazon / Jameco Parts Express
	D5	Diode	1N4001	Amazon / Jameco Parts Express
	D6	Diode	1N4001	Amazon / Jameco Parts Express
	D7	LED	Green (3mm)	Amazon / Jameco Parts Express
	D8	LED	Green (3mm)	Amazon / Jameco Parts Express
	Q1	Transistor	2N2222	Amazon / Jameco
	Q2	Transistor	2N2222	Amazon / Jameco
	Q3	Transistor	2N2222	Amazon / Jameco
	Q4	Transistor	TIP120	Jameco
	Q5	Transistor	TIP120	Jameco
	Q6	Transistor	IR Phototransistor	Amazon / Jameco
	C1	Capacitor	47μF	Amazon / Jameco Parts Express